

NanoBone[®] FIT

NanoBone[®] FIT QD

Synthetic, biodegradable bone graft material



Biocomposites GmbH
Fischerweg 421 | 18069 Rostock | Germany
Tel +49 (0) 381 806 99 40
Fax +49 (0) 381 806 99 49 9
Email: info@biocomposites.com
Web: www.biocomposites.com

Indication

NanoBone[®] FIT is a resorbable implant for filling bone defects that are not essential for the stability of the bone structure and for augmentation. NanoBone[®] FIT can be used wherever the use of autologous cancellous bone would be possible. NanoBone[®] FIT is resorbed and replaced by bone during the healing process.

Properties

NanoBone[®] FIT consists of nanoporous microparticles and a water-soluble carrier containing poloxamer. The nanoporous microparticles are nanocrystalline hydroxyapatite (HA) embedded in silica gel (amorphous SiO₂). Due to the completely synthetic production, a transmission of infections or diseases of animal or human origin is excluded. NanoBone[®] FIT does not harden after implantation.

Application

NanoBone[®] FIT may only be used by qualified personnel with experience in the required surgical techniques. The principles of sterile working and patient medication applicable to the surgical procedure must be observed.

Preparation:

Bone debris and soft tissue located in the defect should be removed from the bone defect to be treated.

Depending on the type and location of the bone defect, additional osteosynthetic measures may be required to stabilize the bone augmentation material. When using NanoBone[®] FIT QD, assemble the applicator as shown in Figure 1 "Preparation of the NanoBone[®] FIT QD applicator".

Implantation:

NanoBone[®] FIT can be used alone or in any mixing ratio with autologous cancellous bone.

The implantation site of NanoBone[®] FIT may need to be properly secured by rigid fixation.

Maximum contact between the patient's bone and NanoBone[®] FIT is required to ensure bone regeneration.

NanoBone[®] FIT does not harden in-situ after implantation.

The bone defect must be completely filled with NanoBone[®] FIT. Overfilling must be avoided, as must compaction of the bone augmentation material in the bone defect.

The filled bone defect must be closed with a primary wound closure, whereby the defect should be covered by the periosteum.

Information

Successful bone regeneration requires the creation of a suitable bone bed (cavity) to prevent dislocation of the NanoBone[®] FIT and immobilization of the bone augmentation material. Micromovements may limit bone regeneration and must be avoided by appropriate surgical techniques (e.g. use of membranes).

Due to its structure, NanoBone[®] FIT exhibits a very low X-ray contrast directly after insertion. In the course of healing, this allows the newly forming bone to be detected in the X-ray image.

NanoBone[®] FIT must not be used after the expiry date.

Warnings

NanoBone[®] FIT is not suitable for load-bearing defects. No data are available on the use of NanoBone[®] FIT in pregnant women or children. To avoid contamination, the sterile bone augmentation material must only be removed from the packaging immediately before use and must be used in a sterile working environment.

Reprocessing of unused NanoBone[®] FIT is not possible, as destruction of the nanostructure and a change in properties cannot be ruled out during reprocessing. For single use only. Reuse and/or re-sterilization of unused NanoBone[®] FIT is not permitted.

Interactions

Interactions of NanoBone[®] FIT with other medical devices or drugs are not known.

Side-effects

Side effects due to the use of NanoBone[®] FIT are not known.

Contraindications

- Acute and chronic infections in the surgical area (soft tissue infections, inflammatory, bacterial bone diseases, osteomyelitis), in the case of antibiotic therapy, the user must decide on the use of NanoBone[®] FIT based on the risk-benefit assessment

- Uncontrolled metabolic diseases (e.g. diabetes mellitus)
- Systemic diseases that negatively impact bone regeneration
- Use of medication known to negatively impact bone regeneration
- Immunosuppressive therapy
- Malignant tumors
- Application in the area of the open epiphyseal joint
- Do not use in mechanically unstable defects (after stabilization of the defect, e.g. with an osteosynthesis plate, it is possible to use NanoBone® FIT)
- In the irradiated area or before a planned irradiation treatment
- Bone defects with absent or deficient vascular supply

Type and content of the package

NanoBone® FIT is available for application as needed in a sterile applicator. This is packaged in a sterile aluminium protective pouch (peel-off pack). The inner pouch is contained in an outer protective aluminium pouch (peel-off pack). Once the inner aluminium protective bag has been opened, NanoBone® FIT must no longer be stored.

Sterility

NanoBone® FIT is sterilized by gamma radiation. The expiry date and the integrity of the sterile packaging must be checked before provision.

A copy of the summary of safety and clinical performance (SSCP) can be requested at infoGermany@biocomposites.com.

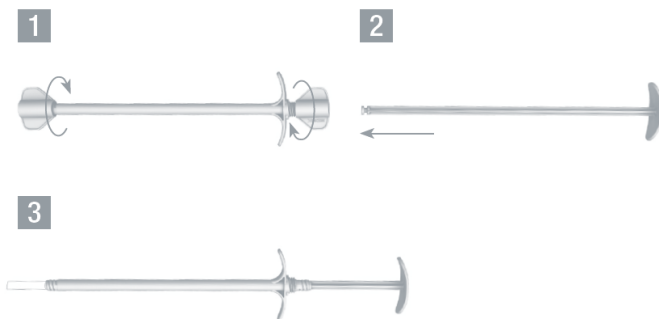

Figure 1: Preparation of the NanoBone® FIT QD applicator